

# CORROSION

## The Use of Metal Within Masonry Wall Systems and Associated Life-Cycle Issues

By Edward Gerns, RA, LEED AP

This article is reprinted from the Proceedings of RCI's 2009 Building Envelope Technology Symposium in San Diego, CA.

### ABSTRACT

The industrial revolution of the late 19th century produced a dramatic change in building construction. The ability to economically manufacture steel shapes led to the development of the skeleton-frame building system. This system enabled the exterior wall to be used as a nonload-bearing component of the building. The façade could be treated as a skin that wrapped the skeletal frame. The skin was still needed to transfer wind loads to the frame and provide weather protection, but it no longer had to support interior floor loads. (See *Figure 1*.)

### INTRODUCTION

See *Figures 2A and 2B*.

The corrosion of exposed iron has long been recognized as a potential problem. The incorporation of iron into masonry construction and subsequent corrosion-related distress have resulted in dramatic changes in the construction and detailing of cladding systems to address water infiltration and corrosion. (See *Figure 3*.)

Numerous methods of limiting corrosion have been employed throughout history, including boiling the iron in tallow, covering it with pitch or varnish, or coating it in molten tin or zinc (otherwise known as galvanizing). Interestingly, research in the early 1900s revealed that some of the substances used as pigment in coatings, such as lead, acted as inhibitors to the corrosion process. It



*Figure 1 – Skeleton-frame building under construction (image from [www.skyscrapercity.com](http://www.skyscrapercity.com)).*

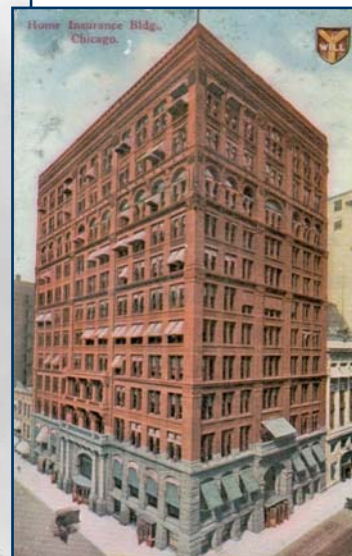

*Figure 2A – The Home Insurance Building, Chicago, generally recognized as the first skyscraper, was built in 1884 (Chicago Tribune image from Google Images).*

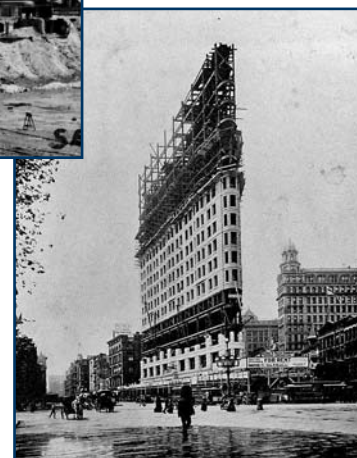

*Figure 2B – In 1931, the Home Insurance Building was demolished to make way for the Field Building (now the LaSalle Bank Building).*



Figure 3 – Distress of masonry cladding resulting from corrosion of embedded steel structure.

was found that the inhibiting coatings provided protection even without a continuous coat. Moisture-barrier coatings, however, relied on the total separation of metal from the atmosphere. More recently, corrosion-resistant materials such as stainless steel and aluminum have been introduced. Careful attention to material selection, detailing, and construction practices can greatly reduce the potential for corrosion-related problems in a new building. The cladding systems in the majority of masonry buildings built prior to 1970 were constructed with corrodible metals. Proper maintenance programs are critical to minimizing the rate of corrosion of embedded metals, but most buildings are not immune to the eventual effects of corrosion.

**INTRODUCTION OF THE CURTAIN WALL**

Cast and wrought-iron structural components had been used prior to 1800, but the limitations of these materials restricted the development of iron-framed structural

systems. Although originally extolled as inexpensive and resistant to both fire and rust, cast iron was a brittle material that lacked tensile strength. Therefore, early buildings with framed structural systems used cast-iron compression components, coupled with wrought-iron beams, which provided much stronger tension and flexure. In the pursuit of enhanced capacity and performance, the use of cast and wrought irons in structural applications was quickly superseded by steel. The material properties of that steel were more consistent than those of iron, with good compression strength, tensile strength, and ductility. Because of this consistency and superior performance, steel was used for both column and beam members in later framed buildings.

Following the development

of mass-produced rolled steel sections in the 1850s, two building framing systems evolved that ultimately led to modern skyscrapers. The cage-building system utilized steel spandrel beams to support both the floor loads and the exterior wall. In a skeleton system, the support of the exterior cladding system was separated from the support of the primary building loads. Both

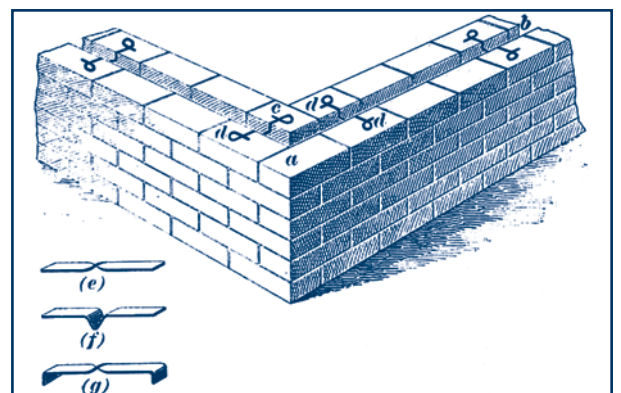

Figure 4 – Early twentieth-century wall system.

the cage and skeleton systems allowed the exterior wall to function as an enclosure rather than as part of the primary structural system. Therefore, the façade could be treated as a skin that wrapped the skeletal frame. This skin or curtain wall was still required to provide weather protection and transfer wind loads to the structural frame but was no longer required to support the interior floor loads (Yeomans, 1993).

### CLADDING MATERIALS

Early skeletal-frame buildings utilized numerous exterior cladding materials. Brick, terra cotta, and stone were all used, with economics frequently dictating both the location and quantity of material. (See Figure 4.)

#### BRICK MASONRY

Early brick walls were typically monolithic. Brick headers were used to tie adjacent wythes together. The popularity of the uniform appearance of the running bond pattern led to alternate methods of creating a monolithic wall. A more reliable system that was more economical than the blind header system was the incorporation of steel or galvanized iron straps or wire ties. (Figure 4). These ties were installed in the bed joints every sixth course.

Even at the turn of the twentieth century, the potential problems of corroding steel were recognized as a shortcoming of the incorporation of metal ties. It was believed, however, that by the time the wire had corroded away, the mortar would have cured to the point to “keep the face brick in place” (Lavicka, 1980).

#### TERRA COTTA

Terra cotta, much like brick, has been used for thousands of years in construction. Limitations of the material, specifically the tendency of the larger pieces to warp, dictated the size of the units and influenced the methods of support and lateral anchorage (Elliot 1993). Horizontal framing members such as shelf angles supported the weight of the terra cotta cladding at each floor level, with terra cotta units bearing directly on the support member and subsequent pieces stacked on the pieces below. These terra cotta units were filled with a combination of mortar and brick and were built concurrently in an attempt to bond and key the facing material to the backup wall. In addition, while the wall was being constructed, various types of bent bars were installed to anchor the terra cotta to

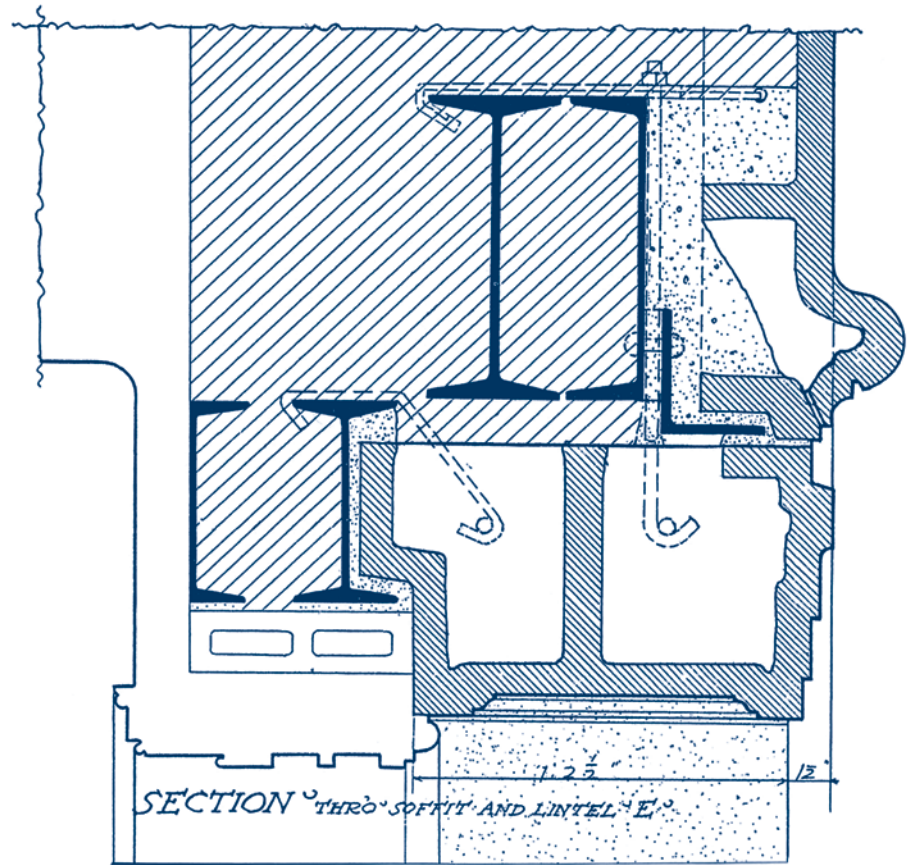

Figure 5 – Terra cotta anchorage details.

the backup and provide stability to the system until the mortar had cured.

In some cases, individual units or entire courses of terra cotta were hung from horizontal supporting members. Hung pieces, such as window lintels, were supported by horizontal bars inserted into holes in the side webs and supported by hooked bars. The hanger hooks, known as J-bolts, were suspended from shelf angles, hooked over the top flange of an embedded structural member, or hooked through a hole in the web of a member. The hooks and bars were protected from corrosion by either galvanizing or a tar coating. Complex terra cotta assemblages, such as cornices, often combined balanced, unbalanced, and hung pieces, requiring an extensive steel framework to provide gravity and lateral support and overturning resistance for the terra cotta (Figure 5).

#### STONE

Historically, stone walls were constructed similarly to brick walls, although the individual stone pieces were larger than bricks. Multiwythe walls were often tied together with stones of alternating thickness to key the system together, similar to a brick header system. Iron cramps were



RCI, Inc.  
800-828-1902  
[www.rci-online.org](http://www.rci-online.org)



Figure 6 – Corroded steel revealed following removal of terra cotta cladding.

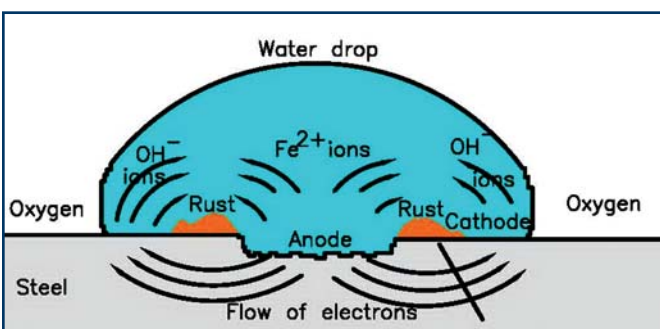

Figure 7 – The corrosion process.

sometimes used to tie individual stone blocks together within a wythe or to tie adjacent wythes (Lavicka, 1980).

The thickness of stone used during the early part of the twentieth century typically varied between four and eight inches, although very expensive stone may have been cut as thin as two inches. The stone was applied as facing to a brick or clay tile backup wall. Lateral anchorage for stone

during this time period was very similar to that of ashlar terra cotta, utilizing a combination of keying and bent bars and rods to tie the facing material to the backup masonry. Individual stones of greater thickness keyed the stone facing into the backup wall. Additionally, Z- or C-shaped steel or iron

cramp anchors were installed to anchor the stone to the backup for larger pieces. One end of the cramp anchors was embedded into the backup, and the other end was inserted into a hole or slot in the top or side of the stone panel.

#### THE CORROSION PROCESS

The rate of corrosion when the pH of a material is between four and ten is essen-

tially constant and relatively low. When the pH falls below four, the rate of corrosion accelerates dramatically. In masonry wall systems, mortar and cement materials initially create an alkaline environment with a pH of approximately ten. As carbon dioxide from the environment penetrates the mortar and causes carbonation, the pH is reduced, resulting in increased corrosion (Craig, 1995). By far the greatest cause of corrosion, however, is water infiltration. (See Figures 6 and 7.)

#### ATMOSPHERIC CORROSION

Atmospheric corrosion is the corrosion mechanism that generally has the greatest impact on masonry construction. Unprotected ferrous metal exposed to the environment in the presence of moisture results in corrosion potential between two points on the surface of the metal. Variability of corrosion will occur with differing electrical potentials on a wet metal surface, possibly



Figure 8 – Complete loss of lateral anchorage.

due to variations in the composition of the metal. Corrosion is most rapid when water covers only a part of the surface and will occur at the interface between the wet and dry areas. The dry portion of the metal is exposed to oxygen and thus becomes the cathode.

#### **GALVANIC CORROSION**

Galvanic corrosion results when two dissimilar metals are in contact with each other. A less noble metal such as steel will corrode, acting as the anode; and the more noble metal, such as copper, will be protected, acting as the cathode. If the surface area of the more noble metal is smaller than that of the less noble metal, the deterioration of the latter is significantly reduced. In terms of building construction, more noble fasteners will generally not corrode when they are in contact with less noble metal substrates; however, the base metal may corrode at the point of contact (Ashurst, 1993).

#### **CORROSION IN MASONRY CONSTRUCTION**

Generally, the corrosion process of metal components within a masonry wall system can be divided into three phases.

Phase one includes the first 30 years of

service life of the building and represents the period of time when the underlying steel is protected by the alkalinity of the environment and various coatings that may have been applied to the steel.

After the initial period, as the protective systems deteriorate, the steel begins to corrode as it is exposed to water and oxygen. Corrosion begins and continues when the moisture content of the masonry exceeds 2% by weight (TAN, 1999). This initiation of corrosion often begins within the first 60 years of service life of a building (TAN, 1999).

After 60 years, the corrosion progresses to the point of visible deterioration and distress such as cracking and displaced masonry resulting from the accumulation of corrosion scale, which occupies a volume of four to 12 times the original volume of the uncorroded metal. Therefore, significant distress will result as the cladding system attempts to accommodate the accumulated scale. The damage resulting from corrosion not only destroys the integrity of the cladding system but also can pose a threat to public safety when cladding failure results in falling materials.

Many different techniques have been developed in an attempt to reduce the

impact of corroding steel. Initial material selection now has the potential to eliminate or greatly reduce the probability of corrosion. Galvanized components, aluminum, and stainless steel have all been utilized as noncorroding systems, but these still have a finite service life.

Maintenance of the building enclosure plays a critical role in the rate of corrosion of the underlying steel as well as the extent of distress resulting from the accumulation of corrosive scale.

#### **DISTRESS CONDITIONS**

Many different types of distress conditions occur as a result of the corrosion of embedded steel components. The following

conditions and repair approaches are not intended to be a comprehensive list of conditions but rather are representative examples of conditions and potential solutions. Any repair design should include careful investigation of the causes of the distress and a thorough evaluation of the repair options.

#### **LOSS OF LATERAL ANCHORAGE**

The deterioration of lateral anchorage within a wall system may be difficult to detect, particularly if the anchors are light-gauge straps that can disintegrate without causing externally visible distress, such as cracking or displacement. The most reliable method for evaluating the condition of these lateral anchors is by direct observation of representative anchors in areas with and without apparent external distress (Figure 8).

#### **GENERALIZED CRACKING**

Cracking in masonry should be carefully evaluated to determine the potential cause or causes. Unaccommodated thermal and moisture expansion, corrosion of supporting steel components, and shrinkage or creep of the structural frame over time may all contribute to cracking of cladding materials. In many instances, cracking resulting

from moisture expansion and frame shrinkage allows moisture to corrode the steel, which in turn causes more cracking. The accumulation of corrosive scale at the cladding supports at each floor level generally leads to distress such as crushing, displacement, and cracking of the masonry cladding materials. Accumulated compressive stresses within the cladding should be relieved as part of a repair program.

#### LOCALIZED CRACKING

##### **Cracked Brickwork.**

Localized, corrosion-related cracking in brickwork is usually the result of corroding shelf angles

and window lintels. This corrosion typically results in characteristic step cracking at window openings or spalling of the face of the brick.

**Cracked Terra Cotta.** Very little corrosion of the embedded anchorage is necessary for cracking of the terra cotta to result, particularly if mortar was packed into the anchorage holes. The resulting crack could propagate to either the external or internal face of the terra cotta. Cracking or spalling toward the back face of the piece is much more difficult to detect with nondestructive techniques.

**Cracked Stone.** As with terra cotta, very little corrosion of the embedded anchors is necessary for cracking of stone panels to occur. Distress can be visible as cracks or spalls on the front face of the stone, or the distress can propagate to the back face, resulting in hidden spalls or cracks behind embedded anchors.

#### DISPLACED MASONRY

Although compressive stresses within the façade (caused by moisture and thermal expansion of the cladding, as well as shrinkage and creep of the structural frame) can also contribute to both localized and overall displacements, in most cases, corrosion of underlying steel contributes to



*Figure 9 – Displaced brickwork.*



RCI, Inc.  
800-828-1902  
[www.rci-online.org](http://www.rci-online.org)



Figure 10 – Installation of flashing system, including end dam to protect underlying shelf angle at window head.

the displacement of masonry cladding materials (Figure 9).

## REMEDIATION AND PREVENTION

### WATER MANAGEMENT

Liquid water control measures are often introduced with various levels of success, depending on the system design and installation. The integrity of the mortar joints between masonry units is one of the most important factors in minimizing water infiltration into a wall system. In addition, flashings can provide a degree of control of moisture penetration in masonry walls. Without properly designed and installed flashings (Figure 10), water that penetrates a wall will not be diverted back to the exterior and can accelerate corrosion. Flashing systems were generally not included in exterior wall systems until the 1940s. Many of the early systems were not effective and may have actually exacerbated the conditions they were intended to mitigate.

Stainless steel, copper, and lead-coated copper are effective and durable flashing materials. A properly designed flashing system can both protect steel support elements as well as direct moisture within the wall to the exterior.

### TREATMENT OF EXISTING METALS

In most instances, the existing lateral anchorage for a masonry wall system consists of discrete elements installed in joints

between adjacent pieces. Where wall systems require repair or reconstruction, rarely is it advisable to reuse these anchors, regardless of their condition. Replacement of existing components with new stainless steel anchors specifically designed for the conditions is almost always advisable.

Evaluation of gravity support elements such as shelf angles and columns is usually more complicated and requires additional consideration. In cases of mild to moder-

ate corrosion, cleaning and painting of the existing steel with a corrosion-inhibiting system (zinc, urethanes, and epoxies) can be an effective repair (Figure 11). In some cases, severely corroded areas can be widespread or directly adjacent to relatively intact areas, requiring either localized repairs or replacement of the piece.

To attach replacement or reinforcing members, field welding can be an economical choice; however, testing for weldability of the existing metal and determination of special procedures that may be required to achieve good quality welds is critical for an effective repair. Special care should be taken following welding processes to ensure that protective coatings are repaired and that crevasses that can hold water and create a potential for future corrosion are not created. When different metals are being welded together, it is critical that they each be evaluated for weldability and potential galvanic corrosion. Field welding also poses a risk of fire, since the welding process can inadvertently ignite interior finish materials or materials hidden within the wall.

Bolting of new pieces of steel to existing steel is the most straightforward method of repair (Figures 12A and 12B). This can be expensive, since access necessary to install the nut at the back of the bolt often requires removal of additional backup materials. Several new anchors that are conceptually similar to pop rivets have been introduced within the past decade to permit one-sided installation and eliminate the need to access both sides of the member.



Figure 11 – Coating of existing steel support with corrosion-inhibiting system.

The newest techniques for repair of damaged steel include adhesive-applied systems. Reinforcement is achieved by gluing high-strength fibers, mesh, or ribbons to damaged members to reestablish structural properties. These techniques remain largely experimental in the United States, but they have gained wider acceptance in Europe. As with any new system, the expected service life and long-term performance of the repairs remain unknown.

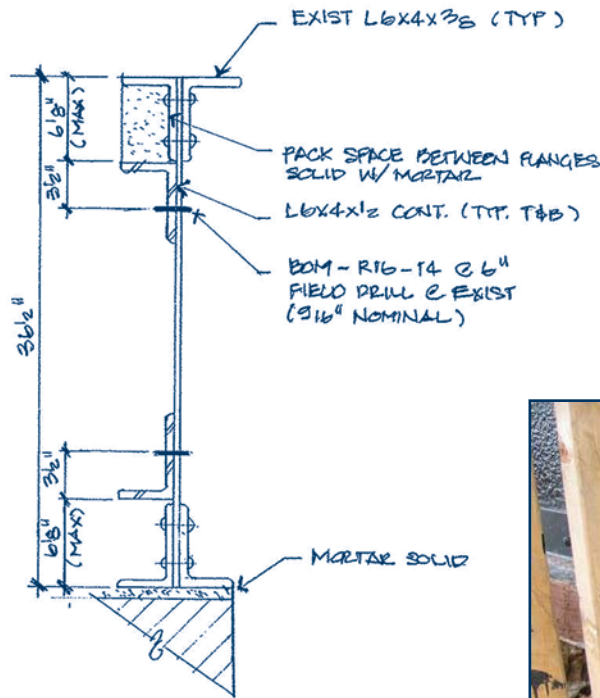

Figure 12A and 12B - Representative example of steel reinforcement.



**SUPPLEMENTAL LATERAL ANCHORAGE**

Supplemental lateral anchors can be installed to reestablish the required lateral anchorage for the wall system. Numerous types of proprietary anchors exist for this purpose. Regardless of the anchor selected, the proposed anchor should be tested to determine the required spacing to ade-



RCI, Inc.  
800-828-1902  
[www.rci-online.org](http://www.rci-online.org)



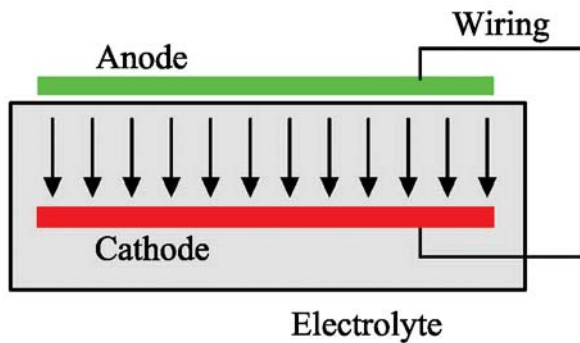

Figure 13 – Galvanic-anode system.

quately resist wind and seismic design criteria. All such anchors should be of stainless steel. Repair anchors may rely on adhesion, friction, or bearing to achieve the necessary structural capacity. Due to the “blind” nature of the installation of repair anchors, variability of the substrate must be considered in developing the spacing and installation criteria. Some anchors will inevitably be installed into voids or into inadequate substrate, rendering them ineffective. Contractors should be sensitized to these issues and be encouraged to notify the architect or engineer should the problem be more serious than anticipated.

Techniques for installing repair anchors should be carefully evaluated to ensure that they do not cause spalling of the back face of the masonry. Special drills with rotary spline drives, which drill holes with minimal hammering action of the bit, should be used if spalling is a potential issue.

#### CATHODIC PROTECTION

The corrosion process of a metal can be effectively halted by providing sufficient electrons to the anode to reverse the reactions at the anode and cathode (corroding steel). Early construction-related applications were used to protect subgrade piping in the 1920s. Prior to that, applications were limited to marine structures. Two systems exist as illustrated above. The galvanic system is an obvious outgrowth of the understanding of galvanic interaction between dissimilar metals (Figure 13) and uses the natural process of the galvanic interaction to protect the embedded steel. More recently, and for larger applications, impressed current systems are more appropriate (Figure 14). These electrochemical techniques, such as cathodic protection, have proven effective in parking garage installations and have been implemented on cladding systems in Europe within the past

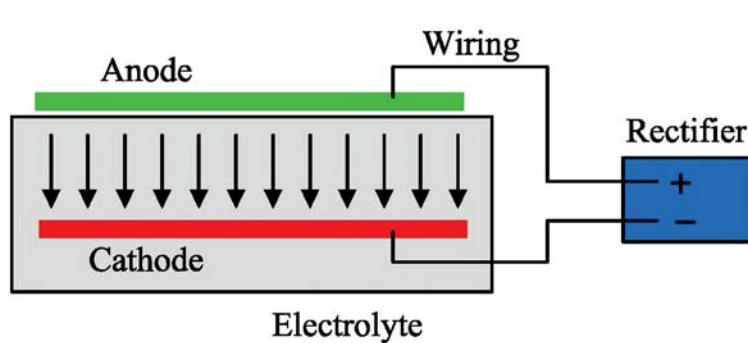



Figure 14 – Impressed-current system.

30 years. Cathodic protection systems are theoretically capable of stopping corrosion, but they cannot reverse the corrosion process. Extensive evaluation of existing conditions, conductivity, and continuity is necessary to determine practicality of installing an effective cathodic protection system.

#### SUMMARY

The lessons that have been learned over the past 130 years regarding corrosion in buildings are important to recognize. Thousands of historically significant buildings will inevitably require some level of intervention to save. Significant pieces of our architectural heritage may be lost if proper measures are not taken to address these buildings. Significant life-cycle cost savings can be realized by performing regular maintenance on them. If both the maintenance and repair of these buildings are performed with the appropriate materials and understanding of the systems, their service life can be greatly increased. 

#### REFERENCES

J. Ashurst, N. Ashurst, *Practical Building Conservation, English Heritage Technical Handbook, Volume 4: Metals*, Gower Technical Press, English Her-

itage, 193, pp. 8-16.

*Corrosion in Masonry-Clad Early 20th Century Steel-Framed Building*, Technical Advice Note 20, Technical Conservation Research and Education Division, Historic Scotland, 1999, pp. 17-20.

B. Craig, *Handbook of Corrosion Data*, ASTM International, Materials Park, OH, 1995, p.11.

Cecil Elliot, *Technics and Architecture: The Development of Materials and Systems for Buildings*, The MIT Press, Cambridge, MA, 1993, pp. 23-73.

C.T. Grimm, “Demolish Charleston’s Brick Walls Because There Is Chloride in the Mortar?” *Journal of Materials in Civil Engineering*, American Society of Civil Engineers, Reston, VA, Vol. 9, No. 3, August 1997, p. 160.

W. Lavicka, *Masonry, Carpentry, Joinery: The Art of Architecture, Engineering and Construction in 1899*, Chicago Review Press, Chicago, IL, 1980, p. 114.

David Yeomans, *Construction Since 1900: Material*, B. T. Batsford Ltd., London, England, 1997, pp. 33-40.

#### Edward Gerns, RA, LEED-AP

Edward Gerns is a principal at Wiss, Janney, Elstner Associates, Inc. (WJE) with over 19 years of experience. Gerns has performed hundreds of investigations and assessments and developed repairs of building façades of all vintages and sizes throughout the U.S. He has investigated and repaired cladding materials, including terra cotta, stone, brick, curtain wall, EIFs, wood siding, and composite materials. He has written numerous papers related to façade assessments and repairs. He is an instructor in a building diagnostics class for the Masters of Historic Preservation degree at the Art Institute of Chicago.

