



# DESIGN OF ANCHOR BOLTS EMBEDDED IN CONCRETE MASONRY

## TEK 12-3C Reinforcement & Connectors (2013)

### INTRODUCTION

The function of anchor bolts is to transfer loads to the masonry from attachments such as ledgers, sills, and bearing plates. Both shear and tension are transferred through anchor bolts to resist design forces such as uplift due to wind at the top of a column or wall or vertical gravity loads on ledgers supporting joists or trusses (see Figure 1). The magnitude of these loads varies significantly with the application.

This TEK summarizes the requirements to properly design, detail and install anchor bolts embedded in concrete masonry construction based on the provisions of the 2013 edition of *Building Code Requirements for Masonry Structures* (ref. 1). It should be noted that the 2012 editions of the *International Building Code* and *International Residential Code* (refs. 3 and 4) reference the provisions of the 2011 edition of *Building Code Requirements for Masonry Structures* (ref. 5) which contain no significant differences from the following analysis and design methodologies.

### Anchorage Types and Configurations

Anchor bolts can generally be divided into two categories: embedded anchor bolts, which are placed in the grout during the masonry construction; and post-installed anchors, which are placed after the masonry is constructed. Post-installed anchors achieve shear and tension (pull out) resistance by means of expansion against the masonry or sleeves or by bonding with epoxy or other adhesives. The design of post-installed anchors should be in accordance with the anchor manufacturer's literature and is beyond the scope of this TEK.

Anchor bolt configurations covered by *Building Code Requirements for Masonry Structures* fall into one of two categories:

- Bent-bar anchors, which include the customary J and L bolts, are threaded steel rods with hooks on the end embedded into the masonry. Bent-bar anchor bolts must meet the material requirements of *Standard Specification for Carbon Structural Steel*, ASTM A36/A36M (ref. 6).

- Headed anchors include conventional square head or hexhead threaded bolts, but also include plate anchors (where a steel plate is welded to the end of the bolt). Headed anchor bolts must meet the requirements of *Standard Specification for Carbon Steel Bolts and Studs, 60,000 psi Tensile Strength*, ASTM A307, Grade A (ref. 7).

For other anchor bolt configurations, including post-installed anchors, design loads are determined from testing a minimum of five specimens in accordance with *Standard Test Methods for Strength of Anchors in Concrete and Masonry Elements*, ASTM E488 (ref. 8) under stresses and conditions that represent the intended use. Allowable stress design values are limited to 20% of the average tested anchor bolt strength. Using strength design provisions, nominal design strengths are limited to 65% of the average tested strength.

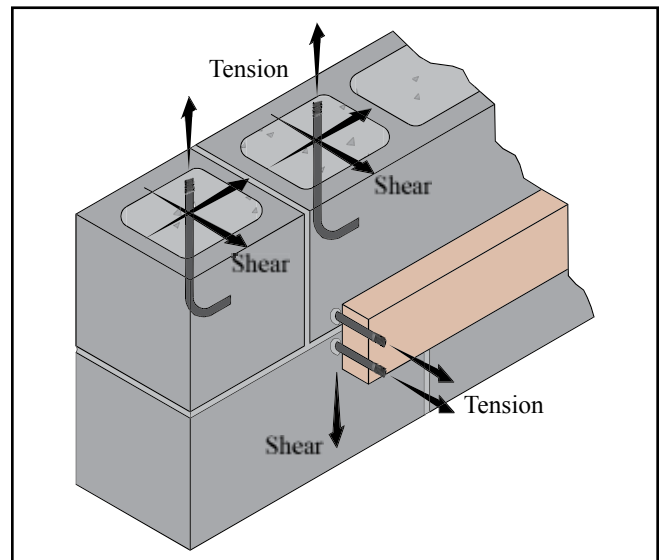

Figure 1—Anchorage Design Loads

### Related TEK:

14-4B, 14-7C

**Keywords:** allowable stress design, anchorage, anchor bolts, bent-bar anchor, connections, design values, headed anchor, strength design

## GENERAL DESIGN AND DETAILING REQUIREMENTS

*Building Code Requirements for Masonry Structures* (ref. 1) contains anchor bolt design provisions for both the allowable stress design and strength design methods (Chapters 2 and 3, respectively). An overview of these design philosophies can be found in *Allowable Stress Design of Concrete Masonry*, TEK 14-7C, and *Strength Design Provisions for Concrete Masonry*, TEK 14-4B (refs. 9, 10). Note that Chapter 5 of the code also includes prescriptive criteria for floor and roof anchorage that are applicable to empirically designed masonry, but these provisions are not covered here.

While many of the requirements for anchor design vary between the allowable stress and strength design methods, some provisions are commonly shared between the two design approaches. The following discussion and topics apply to anchors designed by either the allowable stress or strength design methods.

### Effective Area of Anchor Bolts

For both design methods, the anchor bolt net area used to determine the design values presented in this TEK are taken equal to the following, which account for the reduction in area due to the presence of the anchor threading:

$$\frac{1}{2} \text{ in. anchor} = 0.142 \text{ in.}^2 (91.6 \text{ mm}^2)$$

$$\frac{5}{8} \text{ in. anchor} = 0.226 \text{ in.}^2 (145.8 \text{ mm}^2)$$

$$\frac{3}{4} \text{ in. anchor} = 0.334 \text{ in.}^2 (215.4 \text{ mm}^2)$$

$$\frac{7}{8} \text{ in. anchor} = 0.462 \text{ in.}^2 (298.0 \text{ mm}^2)$$

### Effective Embedment Length

The minimum effective embedment length for anchor bolts is four bolt diameters ( $4d_b$ ) or 2 in. (51 mm), whichever is greater (see Figure 2). The embedment length of headed bolts,  $l_b$ , is measured parallel to the bolt axis from the surface of the masonry to the bolt head bearing surface. For bent-bar anchors, the effective embedment length is measured parallel to the bolt axis from the masonry surface to the bearing surface on the bent end minus one anchor bolt diameter.

### Placement

Anchor bolts are required to be embedded in grout, with the exception that  $\frac{1}{4}$  in. (6.4 mm) diameter anchors are permitted to be placed in mortar bed joints that are at least  $\frac{1}{2}$  in. (12.7 mm) thick. Excluding anchors placed in mortar bed joints, a minimum clearance of  $\frac{1}{4}$  in. (6.4 mm) and  $\frac{1}{2}$  in. (12.7 mm) is required between the anchor bolt and the nearest surface of masonry for fine grout and coarse grout, respectively. This requirement applies to anchor bolts embedded in the top of a masonry element as well as those penetrating through the face shells of masonry as illustrated in Figure 2. While research (ref. 11) has shown that placing anchors in oversized

holes in masonry unit face shells has no significant impact on the strength or performance of anchors compared to those placed in holes only slightly larger than the anchor diameter, the code has opted to maintain these clearance requirements as a convenient means of verifying that grout has adequately consolidated around the anchor bolt.

Although it rarely controls in typical masonry design, *Building Code Requirements for Masonry Structures* also requires that the distance between parallel anchors be at least equal to the diameter of the anchor, but not less than 1 in. (25.4 mm) to help ensure adequate anchor performance and grout consolidation around the anchor.

Existing masonry codes do not address tolerances for anchor bolt placement. In the absence of such criteria, construction tolerances used for placement of structural reinforcement could be modified for application to anchor bolts. In order to keep the anchor bolts properly aligned during grout placement, templates can be used to hold the bolts within the necessary tolerances. Templates, which are typically made of wood or steel, also prevent grout leakage in cases where anchors protrude from the side of a wall.

### Projected Shear and Tension Areas

The projected tension breakout area,  $A_{pt}$ , and the projected shear breakout area,  $A_{pv}$ , for headed and bent-bar anchors are determined by Equations 1 and 2 as follows:

$$A_{pt} = \pi l_b^2 \quad \text{Eqn. 1}$$

$$A_{pv} = \frac{\pi l_{be}^2}{2} \quad \text{Eqn. 2}$$

The anchor bolt edge distance,  $l_{be}$ , is measured in the direction of the applied load from the center of the anchor bolt to the edge of the masonry. When the projected areas of

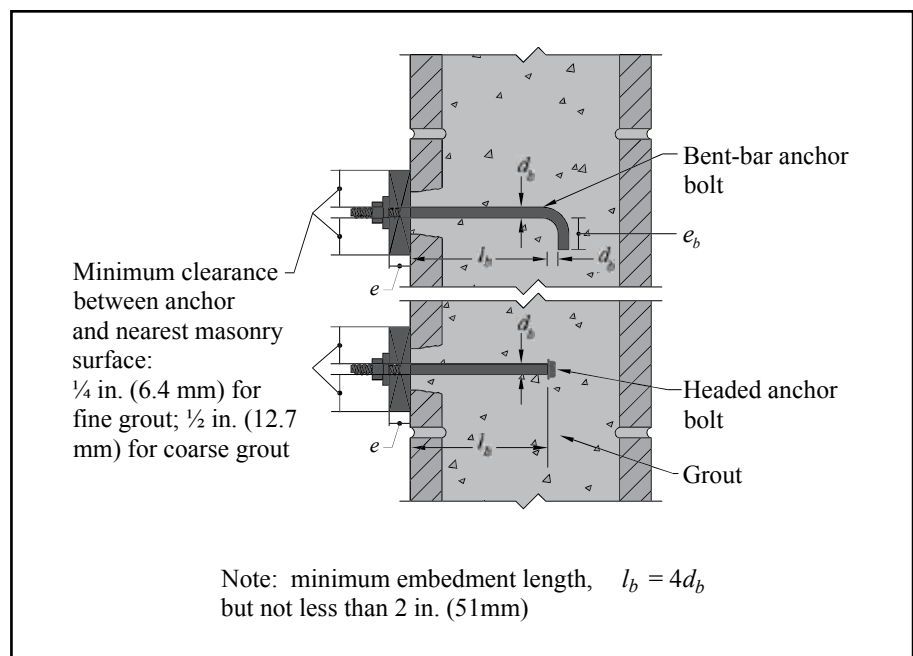

**Figure 2—Minimum Effective Embedment Lengths**

adjacent anchor bolts overlap, the portion of the overlapping area is reduced by one-half for calculating  $A_{pt}$  or  $A_{pv}$ , as shown in Figure 3. Any portion of the projected area that falls within an open cell, open core, open head joint, or falls outside of the masonry element is deducted from the calculated value of  $A_{pt}$  and  $A_{pv}$ . A graphical representation of a tension breakout cone is shown in Figure 4.

## ALLOWABLE STRESS DESIGN OF ANCHOR BOLTS

### Tension

The allowable axial tensile load,  $B_{as}$ , for headed and bent-bar anchor bolts is taken as the smaller of Equation 3, allowable axial tensile load governed by masonry breakout, and Equation 4, allowable axial tensile load governed by anchor yielding. For bent-bar anchors, the allowable axial tensile load must also be less than that determined by Equation 5 for anchor pullout.

$$B_{vb} = 1.25 A_{pt} \sqrt{f'_m} \quad \text{Eqn. 3}$$

$$B_{as} = 0.6 A_b f_y \quad \text{Eqn. 4}$$

$$B_{vs} = 0.6 f'_m e_b d_b + 120\pi(l_b + e_b + d_b)d_b \quad \text{Eqn. 5}$$

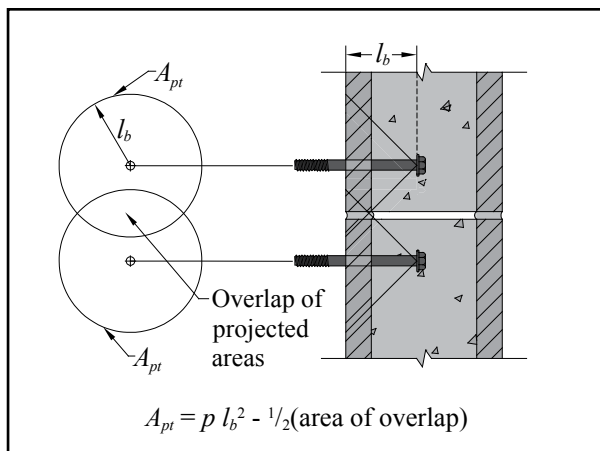

**Figure 3—Reduction of Projected Area When Failure Cones Overlap**

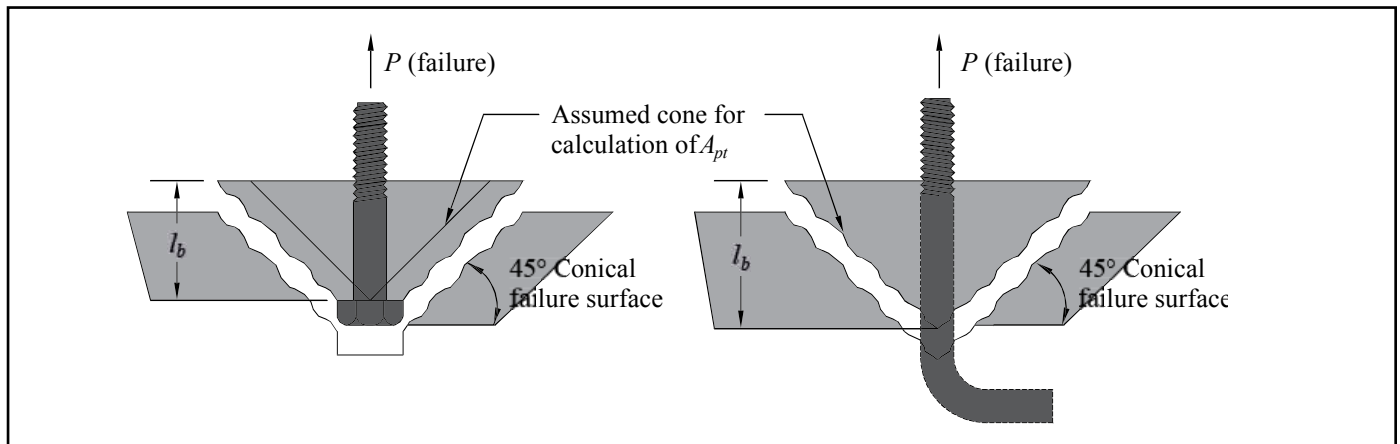

**Figure 4—Assumed Anchor Bolt Failure Cone**

### Shear

The allowable shear load,  $B_s$ , for headed and bent-bar anchor bolts is taken as the smallest of Equation 6, allowable shear load governed by masonry breakout, Equation 7, allowable shear load as governed by crushing of the masonry, Equation 8, allowable shear load as governed by masonry pryout, and Equation 9, allowable shear load as governed by anchor yielding.

$$B_{vb} = 1.25 A_{pv} \sqrt{f'_m} \quad \text{Eqn. 6}$$

$$B_{vc} = 350 \sqrt[4]{f'_m A_b} \quad \text{Eqn. 7}$$

$$B_{vc} = 2.5 A_{pt} \sqrt{f'_m} \quad \text{Eqn. 8}$$

$$B_{vs} = 0.36 A_b f_y \quad \text{Eqn. 9}$$

### Combined Shear and Tension

Anchor bolts subjected to combined axial tension and shear must also satisfy the following unity equation:

$$\frac{b_a}{B_a} + \frac{b_v}{B_v} \leq 1.0 \quad \text{Eqn. 10}$$

The relationship between applied tension and shear loads versus allowable tension and shear loads is illustrated in Figure 5.

## STRENGTH DESIGN OF ANCHOR BOLTS

The design provisions for anchor bolts using the strength design method is nearly identical to that used for allowable stress design, with appropriate revisions to convert the requirements to produce nominal axial tension and shear design strengths. The strength reduction factors,  $\phi$ , for use in Equations 11 through 18 are taken equal to the following values:

- when the nominal anchor strength is controlled by masonry breakout, masonry crushing, or anchor pryout,  $\phi$  is taken equal to 0.50,
- when the nominal anchor strength is controlled by anchor bolt yielding,  $\phi$  is taken equal to 0.90,
- when the nominal anchor strength is controlled by anchor pullout,  $\phi$  is taken equal to 0.65.

## Tension

The nominal axial tensile strength,  $B_{an}$ , for headed and bent-bar anchor bolts is taken as the smaller of Equation 11, nominal axial tensile strength governed by masonry breakout, and Equation 12, nominal axial tensile strength governed by anchor yielding. For bent-bar anchors, the nominal axial tensile strength must also be less than that determined by Equation 13 for anchor pullout.

$$B_{anb} = 4A_{pt}\sqrt{f'_m} \quad \text{Eqn. 11}$$

$$B_{ans} = A_b f_y \quad \text{Eqn. 12}$$

$$B_{anp} = 1.5f'_m e_b d_b + 300\pi(l_b + e_b + d_b)d_b \quad \text{Eqn. 13}$$

## Shear

The nominal shear strength,  $B_{vn}$ , for headed and bent-bar anchor bolts is taken as the smallest of Equation 14, nominal shear strength governed by masonry breakout, Equation 15, nominal shear strength as governed by crushing of the masonry, Equation 16, nominal shear strength as governed by masonry pryout, and Equation 17, nominal shear strength as governed by anchor yielding.

$$B_{vb} = 4A_{pv}\sqrt{f'_m} \quad \text{Eqn. 14}$$

$$B_{vc} = 1050\sqrt[4]{f'_m A_b} \quad \text{Eqn. 15}$$

$$B_{vpry} = 8A_{pt}\sqrt{f'_m} \quad \text{Eqn. 16}$$

$$B_{vs} = 0.6A_b f_y \quad \text{Eqn. 17}$$

## Combined Shear and Tension

As with allowable stress design, anchor bolts subjected to combined axial tension and shear must also satisfy the following unity equation:

$$\frac{b_{af}}{\phi B_{an}} + \frac{b_{vf}}{\phi B_{vn}} \leq 1.0 \quad \text{Eqn. 18}$$

## DESIGN EXAMPLE

Two  $\frac{1}{2}$  in. (12.7 mm) headed anchors comprise a bolted connection for a roof beam to the side of an 8 in. (203mm) masonry wall, see Figure 5 below. The wall has a minimum specified compressive strength,  $f'_m$  of 2,000 psi (13.8 MPa). The bolts have an effective yield stress of 60 ksi (413.7 MPa) with an effective embedment length and spacing between bolts of 6 in. (50.8 mm).

## Allowable Stress Design

It can be assumed that the  $D + L_R$  is the governing load combination. With this, the total design shear force for the connection is 1,600 lb (7.12 kN), with each anchor bolt resisting half of the total load. As is typical with bolted connections subjected to shear, the load is imparted at an offset distance,  $e$  which is equivalent to the additive thickness of the ledger and connector elements. This eccentric load generates a force couple with tensile forces in the anchor and bearing of the masonry wall. Using engineering judgment, the moment arm can be approximated as  $\frac{5}{6}$  times the distance from the center

line of the bolt to the edge of the ledger, denoted as  $x$  for this example. The induced tension force on the entire connection can be calculated as follows:

$$T = \frac{\text{Moment}}{\text{arm}} = \frac{V_e}{(\frac{5}{6})x} = \frac{1,600(2.5 + 0.25)}{(\frac{5}{6})(2.75)} = 1920 \text{ lb (8.54 kN)}$$

Using Equation 1, one can determine the area of tensile breakout for each bolt to be 113.10 in<sup>2</sup> (729.68 cm<sup>2</sup>), however due to the proximity of the bolts to one another, there is an overlap in projected breakout area. To account for this, one must reduce the projected breakout area by one half of the overlap area when analyzing an individual bolt. The modified projected area for each bolt becomes:

$$A_{pt} = \pi l_b^2 - \frac{l_b^2}{2}(\theta - \sin \theta)$$

$$\text{where } \theta = 2 \arccos\left(\frac{s}{2l_b}\right) \left(\frac{\pi}{190}\right) \text{ in radians}$$

Using the above equation, the modified  $A_{pt}$  is found to be 90.99

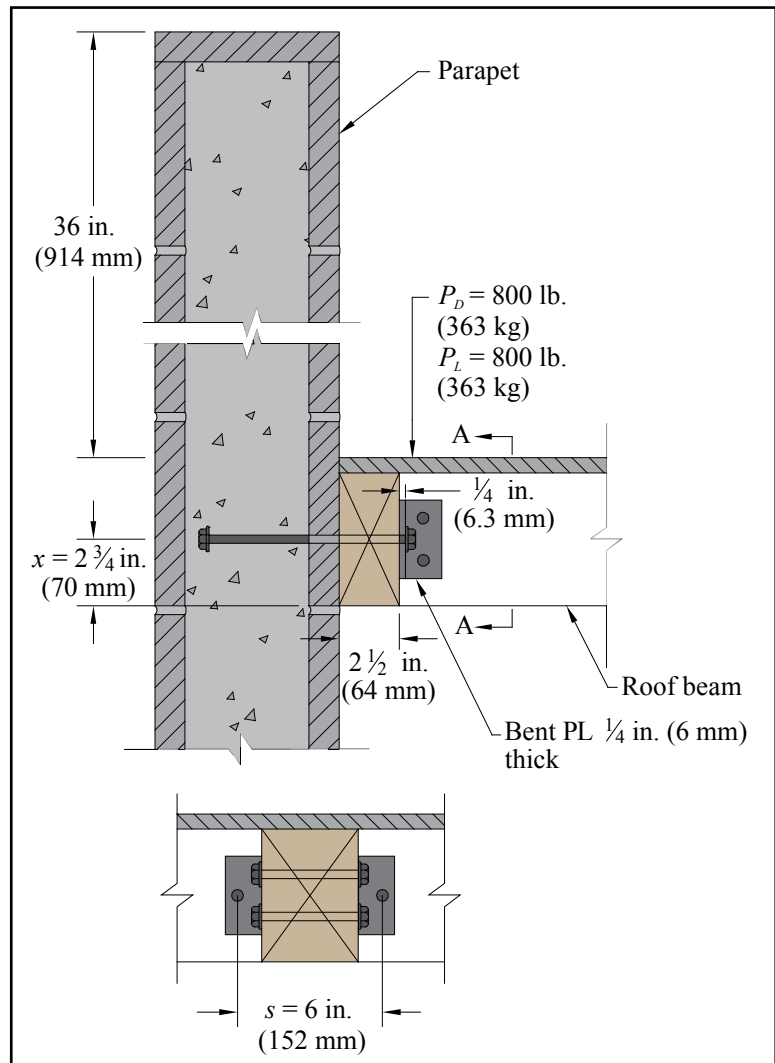

Figure 5—Configuration for Design Example

in<sup>2</sup> (578.03 cm<sup>2</sup>).

In turn, the axial tensile strength is controlled by either masonry breakout (Equation 3) or anchor yielding (Equation 4) and determined as follows (Equation 5 is explicitly for bent-bar anchors and need not be checked):

$$B_{ab} = (1.25)(90.99)\sqrt{2,000} = 5,087 \text{ lb (22.62 kN)}$$

$$B_{as} = 0.6(0.142)(60,000) = 5,112 \text{ lb (22.73 kN)}$$

For this example, the axial tensile strength is controlled by the masonry breakout strength,  $B_{ab}$ .

Similarly, to determine the allowable shear strength, one would typically calculate the shear breakout area for each anchor. For this particular example, given the direction of shear loading and large edge distance, masonry shear breakout will not be the governing failure mode. Calculated strengths for masonry crushing (Equation 7), anchor pryout (Equation 8), and anchor yielding (Equation 9) are as follows:

$$B_{vc} = 350\sqrt{2,000}(0.142) = 1,437 \text{ lb (6.39 kN)}$$

$$B_{vpry} = 2.5(90.00)\sqrt{2,000} = 10,173 \text{ lb (45.24 kN)}$$

$$B_{vs} = 0.36(0.142)(60,000) = 3,067 \text{ lb (13.64 kN)}$$

In this instance, shear strength of each anchor is controlled by the masonry crushing strength,  $B_{vc}$ .

Checking the combined loading effects for an individual anchor against Equation 10 yields the following:

$$\frac{960}{5,036} + \frac{800}{1,437} = 0.190 + 0.557 = 0.747 \leq 1.0$$

Because the demand to capacity ratio is less than 1.0, the design is satisfied.

### Strength Design

It is assumed that the governing load combination for the connection is  $1.2D+1.6L_R$ . With that, the effects of the eccentric shear load are analyzed similarly to the allowable stress design example yielding a factored tensile force of 2,688 lb (11.96 kN) acting on the whole connection. The factored shear load acting on the connection is determined to be 2,240 lb (9.96 kN).

Again, citing Equation 1 and modifying it for the overlap of projected breakout area,  $A_{pt}$  for each anchor bolt is found to be 90.99 in.<sup>2</sup> (578.03 cm<sup>2</sup>). Refer to the allowable stress design example for clarification.

Axial tensile strength determined by calculating masonry breakout (Equation 11) and anchor yielding (Equation 12) are as follows (as was the case before, Equation 13 need not be checked as this applies only to bent-bar anchors):

$$B_{anb} = 4(90.00)\sqrt{2,000} = 16,277 \text{ lb (72.40 kN)}$$

$$B_{ans} = (0.142)(60,000) = 8,520 \text{ lb (37.90 kN)}$$

The nominal axial tensile strength is governed by the anchor yielding,  $B_{ans}$ .

Nominal shear strength is controlled by masonry crushing (Equation 15), anchor pryout (Equation 16), and anchor

yielding (Equation 17) and is checked as follows (as explained previously, for this example the wall geometry and direction of loading indicate shear breakout to be an unlikely failure mode):

$$B_{vnc} = 1,050\sqrt[4]{2,000}(0.142) = 4,310 \text{ lb (19.17 kN)}$$

$$B_{vnpri} = 8(90.00)\sqrt{2,000} = 32,554 \text{ lb (144.81 kN)}$$

$$B_{vns} = 0.6(0.142)(60,000) = 5,112 \text{ lb (22.74 kN)}$$

For this example, the nominal shear strength for each anchor is controlled by masonry crushing,  $B_{vnc}$ .

Applying the appropriate strength reduction factors of  $\phi = 0.9$  for anchor yielding under tensile loads and  $\phi = 0.5$  for masonry crushing under shear loads, and checking the combined loading effects for an individual anchor against Equation 18 yields the following:

$$\frac{1,344}{(0.9)(8,520)} + \frac{1,120}{(0.5)(4,310)} = 0.175 + 0.520 = 0.695 \leq 1.0$$

With the demand to capacity ratio less than 1.0, the design is satisfied.

### ADDITIONAL RESOURCES

A supplemental anchor design spreadsheet has been made available at <http://ncma-br.org/pdfs/41/TEK12-03CABolt.xlsm> for the design of both face and top-mounted masonry anchors in accordance with the 2013 edition of *Building Code Requirements for Masonry Structures*.

### NOTATIONS

- $A_b$  = cross-sectional area of anchor bolt, in.<sup>2</sup> (mm<sup>2</sup>)
- $A_{pt}$  = projected area on the masonry surface of a right circular cone for calculating tensile breakout capacity of anchor bolts, in.<sup>2</sup> (mm<sup>2</sup>)
- $A_{pv}$  = projected area on the masonry surface of one-half of a right circular cone for calculating shear breakout capacity of anchor bolts, in.<sup>2</sup> (mm<sup>2</sup>)
- $B_a$  = allowable axial force on anchor bolt, lb (N)
- $B_{ab}$  = allowable axial tensile load on anchor bolt when governed by masonry breakout, lb (N)
- $B_{an}$  = nominal axial strength of anchor bolt, lb (N)
- $B_{anb}$  = nominal axial tensile strength of anchor bolt when governed by masonry breakout, lb (N)
- $B_{anp}$  = nominal axial tensile strength of anchor bolt when governed by anchor pullout, lb (N)
- $B_{ans}$  = nominal axial tensile strength of anchor bolt when governed by steel yielding, lb (N)
- $B_{ap}$  = allowable axial tensile load on anchor bolt when governed by anchor pullout, lb (N)
- $B_{as}$  = allowable axial tensile load on anchor bolt when governed by steel yielding, lb (N)
- $B_v$  = allowable shear force on anchor bolt, lb (N)
- $B_{vb}$  = allowable shear load on an anchor bolt when governed by masonry breakout, lb (N)
- $B_{vc}$  = allowable shear load on anchor bolt when governed by masonry crushing, lb (N)
- $B_{vnc}$  = nominal shear strength of anchor bolt, lb (N)

$B_{vnb}$  = nominal shear strength of anchor bolt when governed by masonry breakout, lb (N)  
 $B_{vnc}$  = nominal shear strength of anchor bolt when governed by masonry crushing, lb (N)  
 $B_{vnp}$  = nominal shear strength of anchor bolt when governed by anchor pryout, lb (N)  
 $B_{vns}$  = nominal shear strength of anchor bolt when governed by steel yielding, lb (N)  
 $B_{vpry}$  = allowable shear load on an anchor bolt when governed by anchor pryout, lb (N)  
 $B_{vs}$  = allowable shear load on an anchor bolt when governed by steel yielding, lb (N)  
 $b_a$  = unfactored axial force on anchor bolt, lb (N)  
 $b_{af}$  = factored axial force in anchor bolt, lb (N)  
 $b_v$  = unfactored shear force on anchor bolt, lb (N)  
 $b_{vf}$  = factored shear force in anchor bolt, lb (N)

$d_b$  = nominal diameter of anchor bolt, in. (mm)  
 $e$  = eccentricity of applied loads on bolted connection, in. (mm)  
 $e_b$  = projected leg extension of bent bar anchor, measured from inside edge of anchor at bend to farthest point of anchor in the plane of the hook, in. (mm)  
 $f'_m$  = specified compressive strength of masonry, psi (MPa)  
 $f_y$  = specified yield strength of steel for anchors, psi (MPa)  
 $l_b$  = effective embedment length of anchor bolts, in. (mm)  
 $l_{be}$  = anchor bolt edge distance, measured in direction of load, from edge of masonry to center of the cross section of anchor bolt, in. (mm)  
 $s$  = spacing between anchors, in. (mm)  
 $x$  = depth from center line of anchor to edge of ledger  
 $\phi$  = strength reduction factor

## REFERENCES

1. *Building Code Requirements for Masonry Structures*, TMS 402-13/ACI 530-13/ASCE 5-13, Reported by the Masonry Standards Joint Committee, 2013.
2. *Specification for Masonry Structures*, TMS 605-13/ACI 530.1-13/ASCE 6-13, Reported by the Masonry Standards Joint Committee, 2013.
3. *International Building Code*, International Code Council, 2012.
4. *International Residential Code*, International Code Council, 2012.
5. *Building Code Requirements for Masonry Structures*, TMS 402-11/ACI 530-11/ASCE 5-11, Reported by the Masonry Standards Joint Committee, 2011.
6. *Standard Specification for Carbon Structural Steel*, ASTM A36-12, ASTM International, 2012.
7. *Standard Specification for Carbon Steel Bolts and Studs, 60,000 psi Tensile Strength*, ASTM A307-12, ASTM International, 2012.
8. *Standard Test Methods for Strength of Anchors in Concrete and Masonry Elements*, ASTM E488-10, ASTM International, 2010.
9. *Allowable Stress Design of Concrete Masonry*, TEK 14-7C, National Concrete Masonry Association, 2011.
10. *Strength Design Provisions for Concrete Masonry*, TEK 14-4B, National Concrete Masonry Association, 2008.
11. *Testing of Anchor Bolts in Concrete Block Masonry*, Tubbs, J. B., Pollock, D. G., and McLean, D. I., The Masonry Society Journal, 2000.

---

NCMA and the companies disseminating this technical information disclaim any and all responsibility and liability for the accuracy and the application of the information contained in this publication.

---



**NATIONAL CONCRETE MASONRY ASSOCIATION**  
 13750 Sunrise Valley Drive, Herndon, Virginia 20171  
[www.ncma.org](http://www.ncma.org)

---

To order a complete TEK Manual or TEK Index, contact NCMA Publications (703) 713-1900

---